

In combination with
Basic undercarriage
4x2 solid swivel wheels
Input height min. = 800
Input height max. = 1400

In combination with
Basic undercarriage
2x2 pneumatic swivel wheels
Input height min. = 950
Input height max. = 1550

In combination with
Comfort undercarriage
4x2 solid swivel wheels
Input height min. = 800
Input height max. = 1400

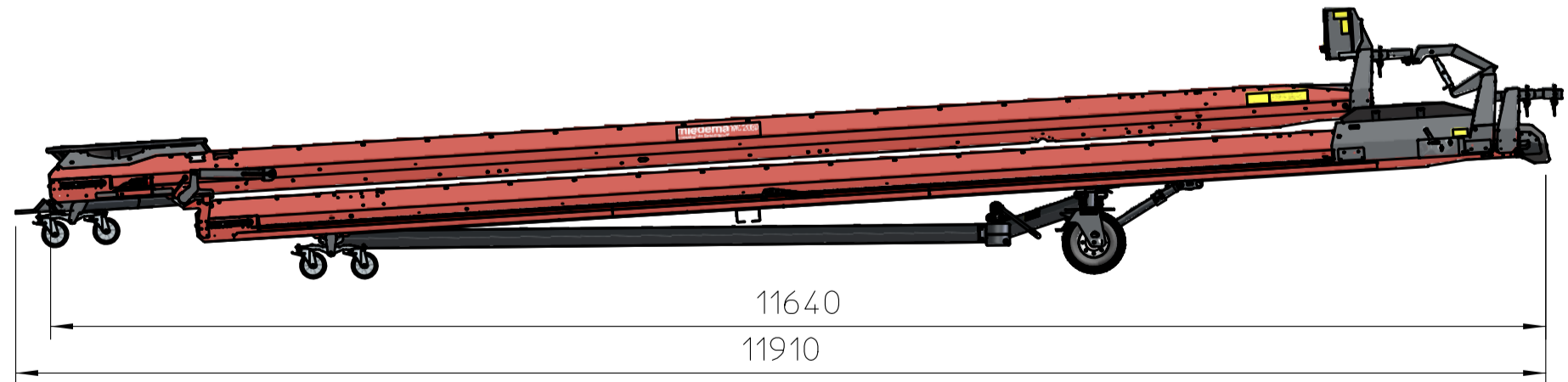
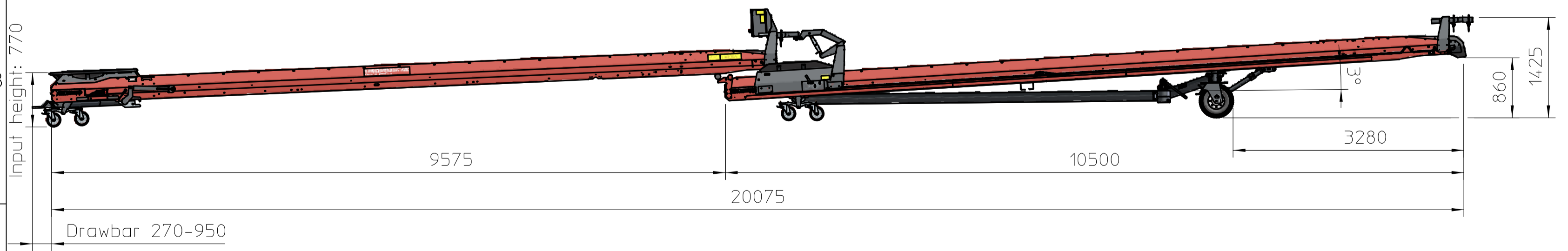
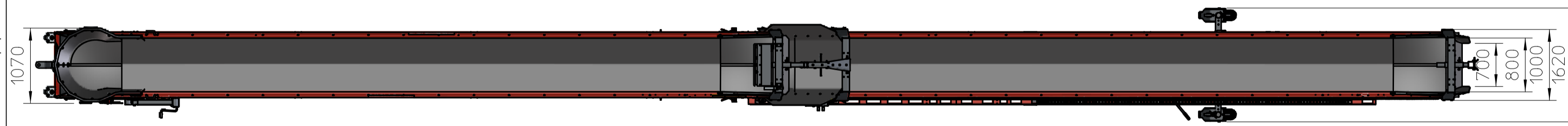

Specifications MC 2080	
Conveyor type	PVC
Conveyor wideness	800mm
Trough angle	35 degrees
Height adjustment	Hydraulic
Capacity	2 speed 120 tonne/hour 200 tonne/hour
Variable belt speed	200 tonne/hour
Input diameter	1000 mm
Voltage	380-420VAC / 50Hz / 3~ 440-480VAC / 60Hz / 3~ 200-220VAC / 60Hz / 3~ 220-240VAC / 60Hz / 3~ 190-210VAC / 50Hz / 3~ 580/620VAC / 60Hz / 3~
Weight	1735 kg
Drawbar load	300 kg
Optional	Electric length adjustment Electric length adjustment with freewheel function Trough to flat set, execution by handle, 4,5m Inspection lighting, 17m cable, 230VAC / 50Hz / 1~ Coupling element output side Coupling element input side Steering rod Forklift sleeve Oil and grease resistant, food safe and blue coloured conveyor belt

dewulf
enjoy growing

Benaming: Duoband MC 80
Tech. omschr.: Maatschets

Alg. ruwheid: 3.2
Lastoleranties ISO 13920 BF
Alg. toleranties ISO 2768-mk
Opp. ruwheid ISO 1302

Laatste wijziging: ()

Opp. beh.: Blank/ruw onbehandeld
Status: approved

Get.: HLS
Gecont.:
Wijz. datum: 13/06/2022
Startdatum: 12/02/2016

Formaat: A1
Tek. nr.: MC 80
Versienr.: 8

Schaal: 1:40
Gewicht: